

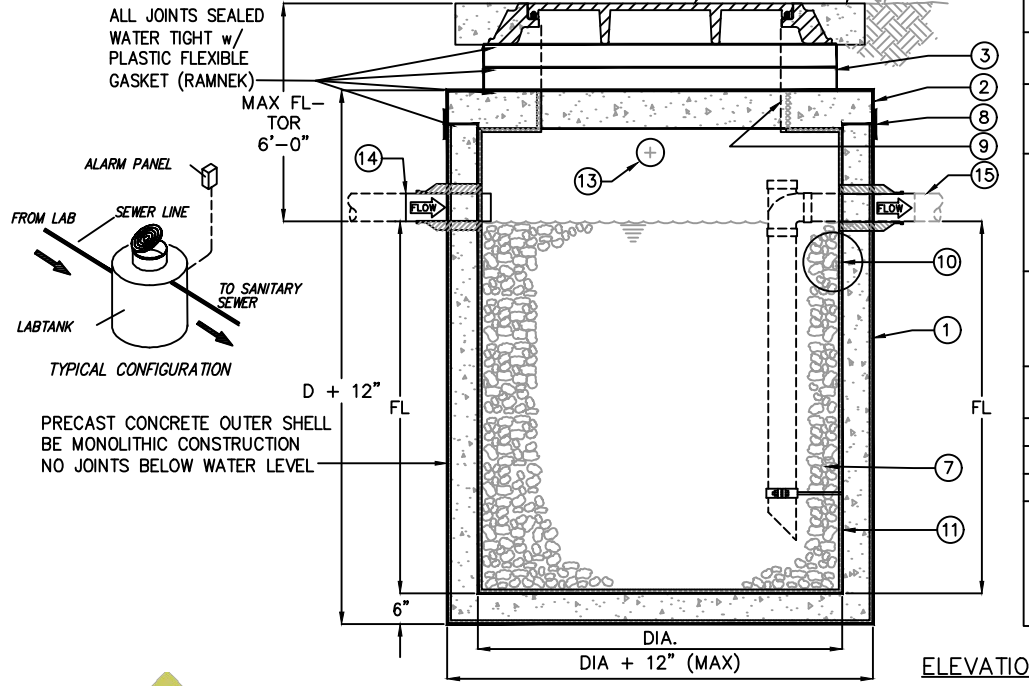

**HOW TO SPECIFY**  
 MODEL NUMBER: ANT [ANT-XX]  
 TANK SIZE (GAL)  
 50 - 50 GAL  
 100 - 100 GAL  
 800 - 800 GAL  
 INTERIOR LINER  
 P - POLYETHYLENE  
 C - CERAMIC BRICK  
 EXTERIOR LINER  
 B - BITUMASTIC  
 P - POLYETHYLENE

DASHED PIPING  
 BY OTHERS

MODEL	GAL	DIA	D	FL	WT lbs.	Flow gal/hr	Lab Stations	Fill cu ft
ANT50	50	36"	30"	18"	2,750	100	10	7
ANT100	100	36"	36"	24"	3,000	200	20	13
ANT150	150	36"	48"	36"	3,500	300	30	20
ANT200	200	36"	60"	48"	4,000	400	40	27
ANT250	250	36"	72"	60"	4,500	500	50	33
ANT275	275	48"	50"	38"	6,500	550	55	37
ANT300	300	48"	54"	42"	6,800	600	60	40
ANT350	350	48"	60"	48"	7,200	700	70	47
ANT400	400	48"	66"	54"	7,650	800	80	53
ANT450	450	48"	72"	60"	8,100	900	90	60
ANT500	500	60"	54"	42"	10,800	1,000	100	67
ANT600	600	60"	62"	50"	11,500	1,200	120	80
ANT700	700	60"	72"	60"	12,100	1,400	140	94
ANT800	800	72"	58"	46"	14,500	1,600	160	107
ANT1000	1,000	72"	68"	56"	14,500	2,000	200	134
ANT1500	1,500	96"	60"	48"	19,600	3,000	300	201
ANT2000	2,000	96"	74"	62"	21,900	4,000	400	267
ANT2500	2,500	96"	88"	76"	24,200	5,000	500	334

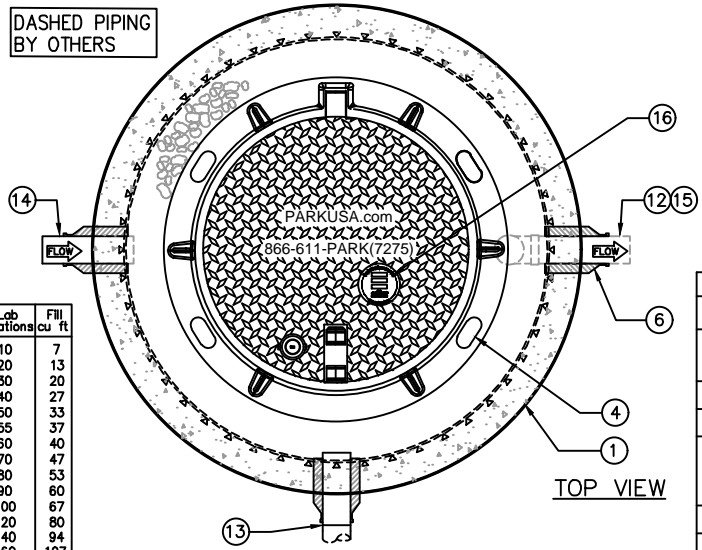

KEYED NOTES		
MARK	QTY	DESCRIPTION
1	1	PRECAST CONCRETE ACID NEUTRALIZATION TANK
2	1	PRECAST CONCRETE TOP™
3	-	CONCRETE EXTENSION (AS REQ'D)
4	1	24" DIA DUCTILE IRON RING/COVER HINGED AND LOCKING. COVER MARKED ACID NEUTRALIZATION BASIN
5	1	CONCRETE APRON (BY OTHERS)
6	3	RUBBER FLEXIBLE PIPE BOOT
7	-	NEUTRALIZING FILL TO CONSIST OF CHEMICAL ROCK OF 1" TO 3" DIA. w/ CALCIUM CARBONATE EQUIVALENT IN EXCESS OF 92%
8	1	4" EXTERNAL JOINT WRAP AROUND PERIMETER
9	1	NON-WETTED INTERIOR OF TANK TO BE COATED w/ ACID RESISTANT EPOXY
10	1	INTERIOR OF TANK (WALLS & BOTTOM) SHALL BE LINED WITH EITHER H.D. POLYETHYLENE 3/8" THK OR CERAMIC BRICK LINING 2" THK (ENGINEER TO CHOOSE ONE)
11	1	EXTERIOR OF TANK TO BE LINED WITH EITHER BITUMASTIC VAPOR BARRIER OR H.D. POLYETHYLENE 3/8" THK (ENGINEER TO CHOOSE ONE)
12	1	ACID WASTE PIPING, BY OTHERS (REFER TO PIPE SPECIFICATIONS)
13	1	XX" VENT
14	1	XX" INLET PIPING
15	1	XX" OUTLET PIPING
16	1	NAMEPLATE MFG: PARKUSA 888-611-PARK WWW.PARKUSA.COM MODEL: ANT-XXXXX DATE MANUFACTURED

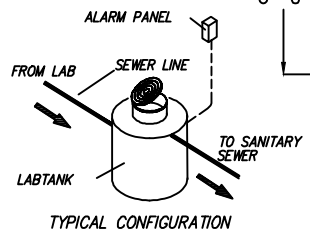

ALL JOINTS SEALED WATER TIGHT w/ PLASTIC FLEXIBLE GASKET (RAMNEK)  
 MAX FL-TOP 6'-0"  
 D + 12"  
 FL  
 6"  
 DIA.  
 DIA + 12" (MAX)  
 GRADE



**Specifications**

- CONCRETE:** Class I/II concrete with design strength of 4500 PSI at 28 days. Unit is of monolithic construction at floor and first stage of wall with sectional riser to required depth.
- REINFORCEMENT:** Grade 60 reinforced with steel rebar conforming to ASTM A615 on required centers or equal.
- D.I. CASTINGS:** Manhole frames, covers or grates are manufactured of ductile iron conforming to ASTM A536, AASHTO M306, & AASHTO M105 Standards. Manhole shall be nominal 24" diameter and be traffic duty.

**Engineering Data**

Neutralization tank is structurally and hydraulically engineered conforming to Uniform Plumbing Code. Refer to Sizing Table for capacity.  
 Field excavation and preparation shall be completed prior to delivery of interceptor. Use dimensional data as shown.

© ParkUSA. ALL RIGHTS RESERVED.

**ACID NEUTRALIZATION TANK**  
 MODEL ANT SIZES 50-2500 GALLONS

PM	PC	DRN	ENG	DWG. NO.	REV.
				ANT-01	A
DATE					

PLOTTED ON 5/15/2023 8:44 AM BY Howerton, Chris. Y:\Perkins\Website 2022 - NEED TO GO VANT worked on VANT-01