

**HOW TO SPECIFY**  
 MODEL NUMBER: ANT XXX-XX

TANK SIZE (GAL)  
 50 - 50 GAL  
 100 - 100 GAL  
 450 - 450 GAL

INTERIOR LINER  
 P - POLYETHYLENE  
 C - CERAMIC BRICK

EXTERIOR LINER  
 B - BITUMASTIC  
 P - POLYETHYLENE

DASHED PIPING  
 BY OTHERS



SIZING TABLE		Flow gal/hr	Lab Stations	Fill cu ft	
MODEL	GAL	DIA	D	FL	WT lbs.
ANT50	50	36"	30"	18"	2,750
ANT100	100	36"	36"	24"	3,000
ANT150	150	36"	48"	36"	3,500
ANT200	200	36"	60"	48"	4,000
ANT250	250	36"	72"	60"	4,500
ANT275	275	48"	50"	38"	6,500
ANT300	300	48"	54"	42"	6,800
ANT350	350	48"	60"	48"	7,200
ANT400	400	48"	66"	54"	7,650
ANT450	450	48"	72"	60"	8,100
ANT500	500	60"	54"	42"	10,800
ANT600	600	60"	62"	50"	11,500
ANT700	700	60"	72"	60"	12,100
ANT800	800	72"	58"	46"	14,500
ANT1000	1,000	72"	68"	56"	14,500
ANT1500	1,500	96"	60"	48"	19,600
ANT2000	2,000	96"	74"	62"	21,900
ANT2500	2,500	96"	88"	76"	24,200

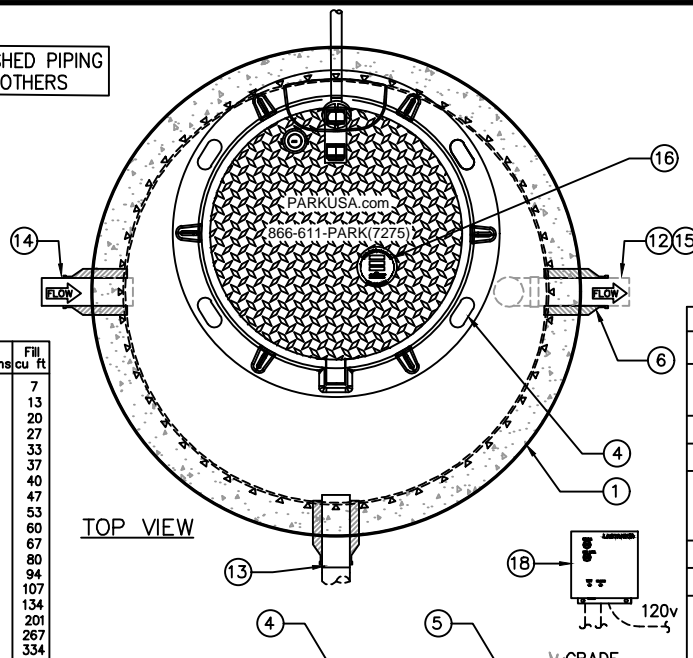

TOP VIEW

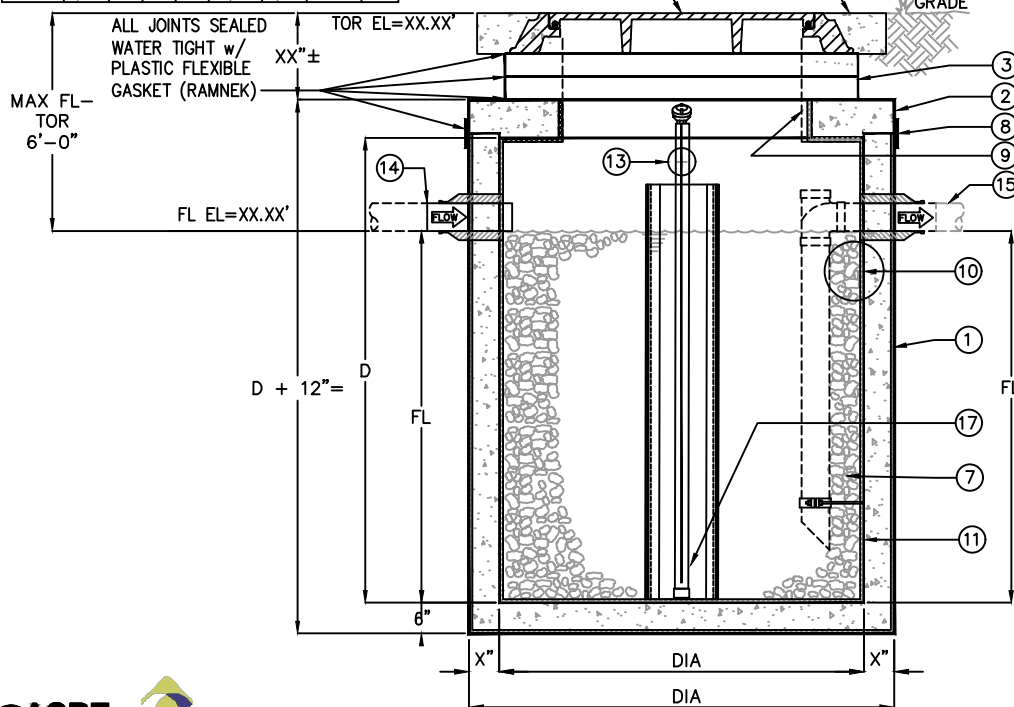

ELEVATION

KEYED NOTES		
MARK	QTY	DESCRIPTION
1	1	PRECAST CONCRETE ACID NEUTRALIZATION TANK
2	1	PRECAST CONCRETE TOP
3	-	CONCRETE EXTENSION (AS REQ'D)
4	1	24" DIA DUCTILE IRON RING/COVER HINGED AND LOCKING. COVER MARKED ACID NEUTRALIZATION BASIN
5	1	CONCRETE APRON (BY OTHERS)
6	3	RUBBER FLEXIBLE PIPE BOOT
7	-	NEUTRALIZING FILL TO CONSIST OF CHEMICAL ROCK OF 1" TO 3" DIA. w/ CALCIUM CARBONATE EQUIVALENT IN EXCESS OF 92%
8	1	4" EXTERNAL JOINT WRAP AROUND PERIMETER
9	1	NON-WETTED INTERIOR OF TANK TO BE COATED w/ ACID RESISTANT EPOXY
10	1	INTERIOR OF TANK (WALLS & BOTTOM) SHALL BE LINED WITH EITHER H.D. POLYETHYLENE 3/8" THK OR CERAMIC BRICK LINING 2" THK (ENGINEER TO CHOOSE ONE)
11	1	EXTERIOR OF TANK TO BE LINED WITH EITHER BITUMASTIC VAPOR BARRIER OR H.D. POLYETHYLENE 3/8" THK (ENGINEER TO CHOOSE ONE)
12	1	ACID WASTE PIPING, BY OTHERS (REFER TO PIPE SPECIFICATIONS)
13	1	XX" VENT
14	1	XX" INLET PIPING
15	1	XX" OUTLET PIPING
16	1	NAMEPLATE MFG: PARKUSA 888-611-PARK WWW.PARKUSA.COM MODEL: ANT-PH-XXXX DATE MANUFACTURED
17	1	LEAK DETECTION PROBE
18	1	LEAK DETECTION ALARM PANEL



**Specifications**

**CONCRETE:** Class I/II concrete with design strength of 4500 PSI at 28 days. Unit is of monolithic construction at floor and first stage of wall with sectional riser to required depth.

**REINFORCEMENT:** Grade 60 reinforced with steel rebar conforming to ASTM A615 on required centers or equal.

**D.I. CASTINGS:** Manhole frames, covers or grates are manufactured of ductile iron conforming to ASTM A536, AASHTO M306, & AASHTO M105 Standards. Manhole shall be nominal 24" diameter and be traffic duty.

**Engineering Data**

Neutralization tank is structurally and hydraulically engineered conforming to Uniform Plumbing Code. Refer to Sizing Table for capacity.

Field excavation and preparation shall be completed prior to delivery of interceptor. Use dimensional data as shown.

© ParkUSA. ALL RIGHTS RESERVED.



**ACID NEUTRALIZATION TANK**  
 MODEL ANT SIZES 50-2500 GALLONS

PM	PC	DRN	ENG	DWG. NO.	REV.
				ANT-PH-01	A
DATE					

PLOTTED ON 5/15/2023 8:44 AM BY Howerton, Chris. Y:\Peridings\Website 2022 - NEED TO GO\ANT\worked on\ANT-01