

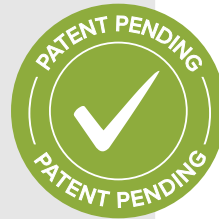

The Big Rolling Tipper™

A cost-effective way to collect, dewater, transport, and dump sludges, slurries, and wet solids.

The Big Rolling Tipper™ is a mobile dewatering system for dewatering WWTP sludge, WTP sludge, septage, grease trap waste, and other industrial waste streams. It is available in either an AquaCat™ model (for flocculation applications) or SludgeKing II™ model (offering increased filtration technology).



Features:

- Available in AquaCat™ or SludgeKing™ models
- PolyCat™ polymer system may be installed on the nose of the trailer
- Bulldog hitch, pintle hitch, gooseneck, or fifth wheel towing
- Available capacities: 3 cubic yards to 30 cubic yards
- Unit sizes 15 cubic yards or less are battery operated; larger units are operated via PTO on the truck
- Optional: hydraulically operated rear door with lock/unlock and open/close functions
- Tilt angle: 45 degrees standard; greater angles up to 50 degrees available
- DOT compliant with standard highway lighting
- 16.5" wheels - 16 ply tandem axles and leaf springs (dual tandem axles on larger units)
- Heavy-duty carbon steel frame
- Electric over hydraulic brakes standard
- Landing gear included

Related Products:



The Little Tipper™



PolyCat™ System

Applications Include:

- Bio-solids dewatering
- Grease trap waste
- Septic tank sludge
- Alum and ferric sludge
- Lagoon sludge
- Tailings pond sludge
- Fly ash

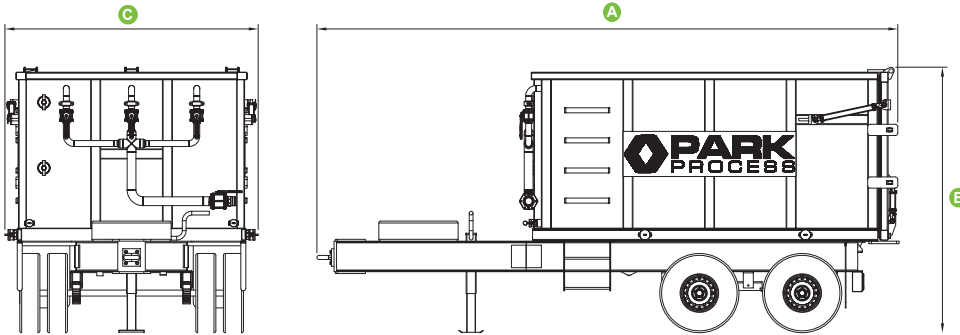

Based on pintle hitch design, Big Rolling Tipper without a PolyCat unit, tarp, or peaked roof will have the following dimensions and weight:

Container Size	A	B	C	Weight (Approx.)
3 yd.	156"	76"	75"	4,500
5 yd.	162"	76"	78"	5,500
10 yd.	200"	102"	102"	9,500
15 yd.	232"	102"	102"	12,000
20 yd.	260"	102"	102"	15,000
25 yd.	330"	102"	102"	18,000
30 yd.	350"	102"	102"	20,000

*Specifications subject to change without notice. Measurements are in inches and weights in pounds.

Amount of 1% sludge Big Rolling Tipper can process before being unloaded (depending on sludge characteristics):

Container Size	Amount
3 yd.	2,800 gal.
5 yd.	4,500 gal.
10 yd.	9,000 gal.
15 yd.	14,000 gal.
20 yd.	18,000 gal.
25 yd.	22,000 gal.
30 yd.	27,000 gal.

Cake dump capacities of Big Rolling Tipper hoists (approximate, excluding the weight of the container):

Container Size	Cake Dump
3 yd.	3,200 lbs.
5 yd.	6,400 lbs.
10 yd.	12,800 lbs.
15 yd.	19,200 lbs.
20 yd.	25,600 lbs.
25 yd.	32,000 lbs.
30 yd.	41,600 lbs.

