

AUTOMATIC OIL STOP VALVE

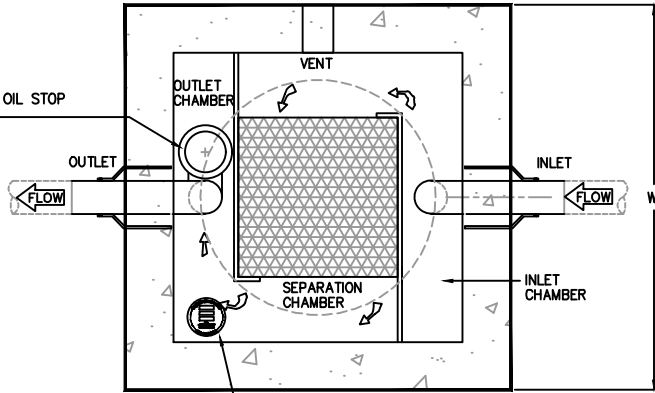

PLAN VIEW

NAMEPLATE INDICATING:
MFG: PARKUSA
888-611-PARK
WWW.PARK-USA.COM
MODEL: CMP
DATE MANUFACTURED

CMP-XXXX-XXX

- SEPARATOR SIZE
- 100 - 100 GALLON
 - 150 - 150 GALLON
 - 200 - 200 GALLON
 - 350 - 350 GALLON
 - ETC...
- MAXIMUM FLOW RATE
- 5 - 5 GPM
 - 10 - 10 GPM
 - ETC...

SAND-OIL INTERCEPTOR SCHEDULE									
MODEL NO.	CAPACITY USGal	OIL CAP. US (GAL)	FLOW RATE (GPM)	EMPTY WT (LBS)	LENGTH L1	WIDTH W1	HEIGHT H1	INLET FL1	OUTLET FL2
CMP-100	100	50	10	5,200	42"	42"	54"	35"	32"
CMP-150	150	75	15	5,438	42"	42"	60"	41"	38"
CMP-200	200	100	20	6,600	48"	48"	60"	45"	42"
CMP-250	250	125	25	7,500	48"	48"	72"	53"	50"
CMP-300	300	150	30	8,475	60"	60"	54"	39"	36"
CMP-400	400	200	40	9,150	60"	60"	60"	45"	42"

OTHER SIZES ARE AVAILABLE. CONTACT US FOR MORE INFORMATION

APPLICATIONS

- MAINTENANCE WASHDOWN & GARAGES
- GOLF COURSES
- EQUIPMENT & TRANSPORTATION WASHDOWN FACILITIES
- CARWASHES
- STORMWATER RUNOFF
- SERVICE STATION FUEL DEPOTS
- MANUFACTURING FACILITY EFFLUENT WATER
- REMEDIATION WATER CLEANUP
- GENERAL INDUSTRY

HIGH OIL ALARM PANEL MOUNTED AT REMOTE LOCATION

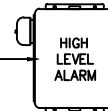

HIGH OIL FLOAT SWITCH

GRADE

GUARANTEED PERFORMANCE

A certified performance analysis utilizing a proprietary computer program will accurately model systems to ensure that their effluent qualities meet the required discharge criteria (EPA and Local Codes)

Influent oily water contains oil droplets of many different sizes. These droplets rise at different rates. Park utilizes a statistical program that divides the droplets into ranges of sizes and calculates the rise rates of each range. This calculation determines which droplets the separator can capture.

Contact our Engineering Dept. @ 800-256-8041 for a free performance evaluation.

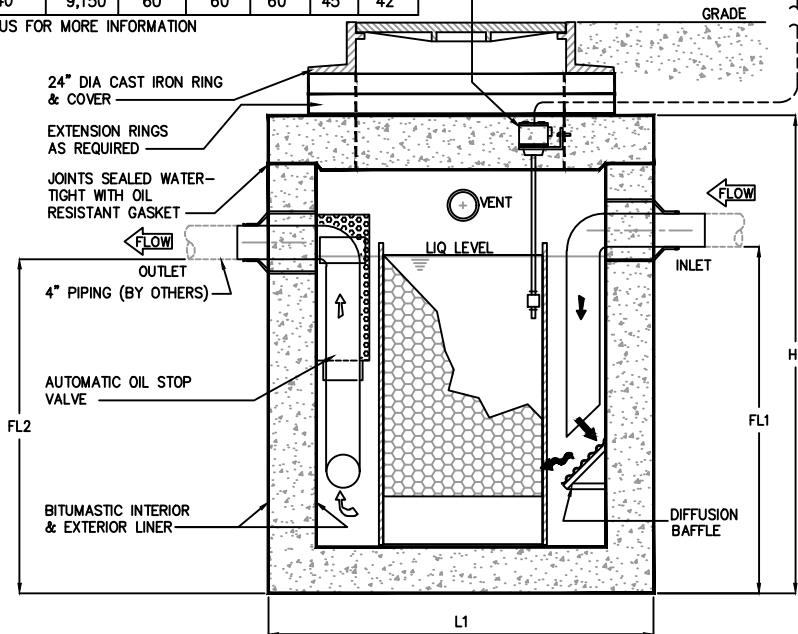

ELEVATION

GUARANTEED PERFORMANCE FOR CODE MAXIMUM OIL CONCENTRATION (SANITARY SEWER 100 PPM, STORM SEWER 15 PPM)

SPECIFICATIONS

- CONCRETE: CLASS I/II CONCRETE WITH OF DESIGN STRENGTH OF 4500 PSI AT 28 DAYS. UNIT IS OF MONOLITHIC CONSTRUCTION AT FLOOR AND FIRST STAGE OF WALL WITH SECTIONAL RISER TO REQUIRED DEPTH. RATED FOR H-20 LOADING.
- REINFORCEMENT: GRADE 60 REINFORCED. NO. 4 STEEL REBAR TO CONFORM TO ASTM A615 ON REQUIRED CENTERS OR EQUAL. BAR BENDING AND PLACEMENT SHALL CONFORM THE LATEST ACI STANDARDS.
- C.I. CASTINGS: CAST IRON RINGS AND GRATES ARE MANUFACTURED OF GREY CAST IRON CONFORMING TO ASTM A48-76 CLASS 30.

ENGINEERING DATA

INTERCEPTOR IS STRUCTURALLY AND HYDRAULICALLY ENGINEERED CONFORMING TO UNIFORM PLUMBING CODE. NOMINAL TOTAL LIQUID CAPACITY AND OIL HOLDING CAPACITY AS INDICATED. RECOMMENDED FOR FLOW RATES OF 5 TO 25 GPM (CONSULT PARK FOR PROPER SIZING). MANUFACTURER SHALL SUBMIT PERFORMANCE CALCULATIONS FOR OIL & WATER SEPARATION CERTIFIED BY A LICENSED PROFESSIONAL ENGINEER. FIELD EXCAVATION AND PREPARATION SHALL BE COMPLETED PRIOR TO DELIVERY OF INTERCEPTOR. USE DIMENSIONAL DATA AS SHOWN.



© ParkUSA. ALL RIGHTS RESERVED.



SAND OIL SEPARATOR
MODEL CMP 100 THRU 400 GALLONS

PM	PC	DRN	ENG	DWG. NO.	REV.
				CMP-1	A
DATE				2023	

PLOTTED ON 5/2/2023 10:08 AM BY Howerton, Chris. Y:\Partidraw\Website 2022 - NEED TO GO\CMP\CMP-1