

FLOATABLE
COLLECTION SCREEN,
GALVANIZED STEEL,
2"x¼" BARS @ 3"
O.C. 2¾" CLEAR
OPENING

NAMEPLATE INDICATING:
PARK USA
888-611-PARK
WWW.PARK-USA.COM
MODEL: DSHD-HC
DATE MANUFACTURED

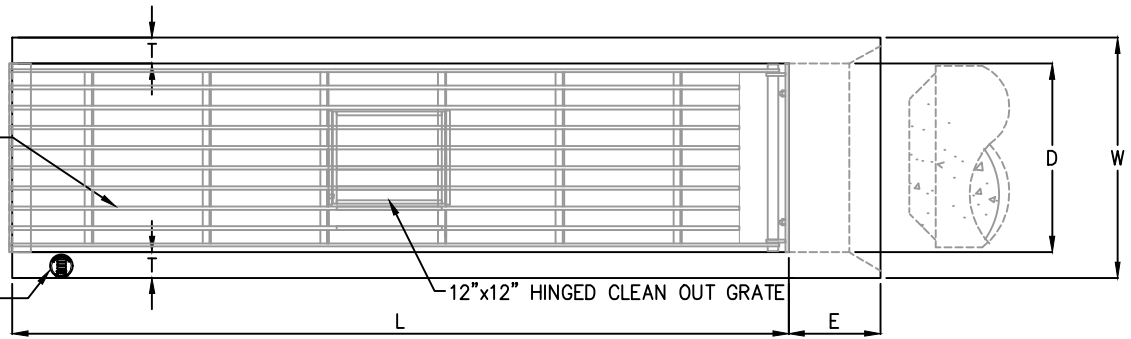

2"x¼" GALVANIZED
ANGLE BOLTED TO
CONCRETE WITH ½"
ANCHOR BOLTS

PRECAST CONCRETE
SLOPE STRUCTURE

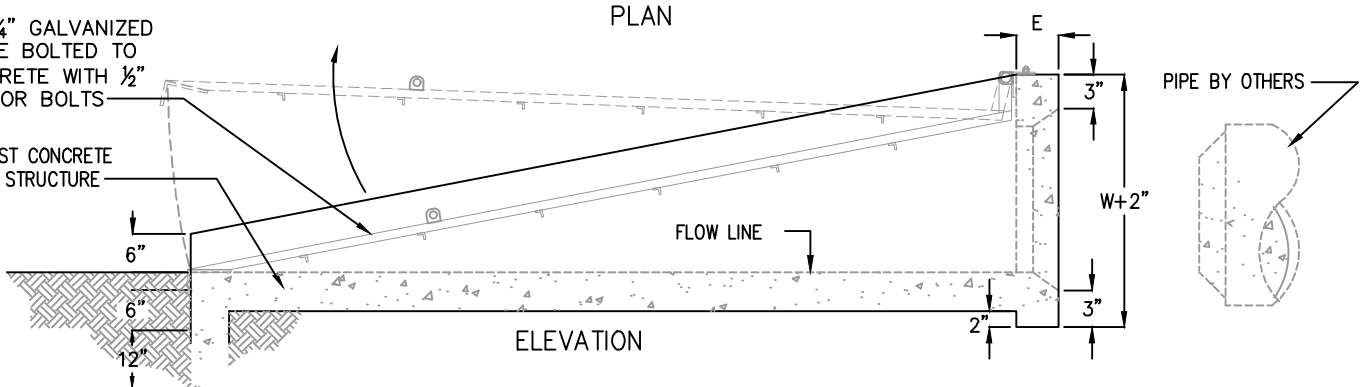

MODEL	D	SLOPE	SCREEN AREA SQ. FT.	W	L	T	E	WEIGHT
DSHD-12-3	12"	3:1	3.25	2'-1¼"	4'-4"	5"	12"	1680
DSHD-15-3	15"	3:1	5.00	2'-1¼"	4'-4"	5"	12"	1680
DSHD-18-3	18"	3:1	7.13	2'-5¼"	4'-9"	5"	12"	2120
DSHD-24-3	24"	3:1	12.50	2'-11½"	6'-3"	5"	12"	3120
DSHD-30-3	30"	3:1	19.38	3'-5¼"	7'-9"	5"	12"	4280
DSHD-36-3	36"	3:1	30.00	4'-3"	10'-0"	6"	12"	6200

DESIGN NOTES:

- DESIGN FOR ACCESSIBILITY BY HCFCO MAINTENANCE PERSONNEL
- SCREEN TO BE DESIGNED FOR HAND RAKING OF DEBRIS TO TOP OF STRUCTURE FOR DEWATERING & TRUCK PICK UP.
- 4' MINIMUM CONCRETE PAVED ACCESS ON ALL SIDES FOR MAINTENANCE PERSONNEL. (BY OTHERS)
- 3:1 MAXIMUM SLOPE FOR TRASH COLLECTION SCREEN & PAVING.
- PROVIDE ALL-WEATHER ACCESS ROAD TO SCREEN & DEBRIS REMOVAL SITE. (BY OTHERS)
- SCREEN SIZE & NET OPENING AREA TO ALLOW FLOW RATE OF 1.0 CFS THROUGH SCREEN, ASSUMING NO BLINDING, SIZE AREA BELOW RESTRICTOR WALL FOR 10 YEAR FLOW RATE & OVERALL SCREEN AREA FOR 100 YEAR FLOW RATE.
MINIMUM SCREEN AREA (SQ FT) = Q (cfs) / 0.92
- SCREEN DESIGN MAY REQUIRE MULTIPLE PANELS.

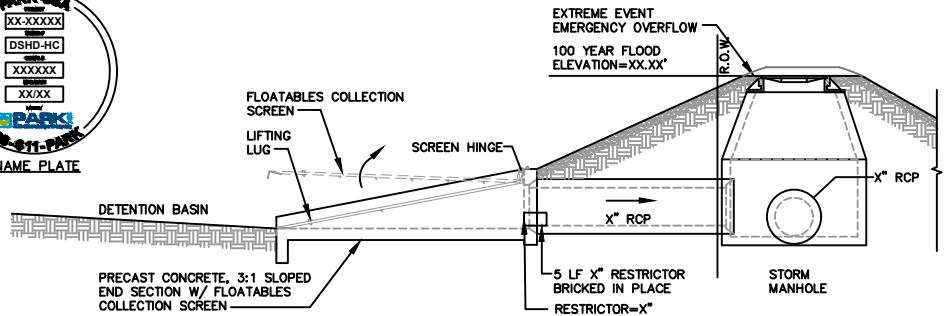
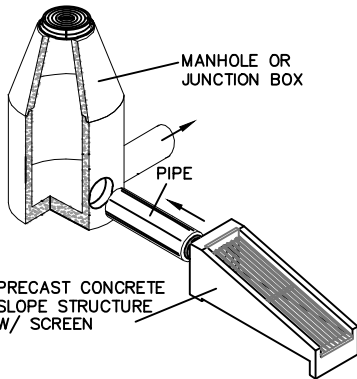

APPLICATION

SPECIFICATIONS

CONCRETE: CLASS I/II CONCRETE WITH OF DESIGN STRENGTH OF 4500 PSI AT 28 DAYS. UNIT IS OF MONOLITHIC CONSTRUCTION INCLUDING WALLS AND FLOOR.

REINFORCEMENT: GRADE 60 REINFORCED. NO. 4 STEEL REBAR TO CONFORM TO ASTM A615 ON REQUIRED CENTERS OR EQUAL. BAR BENDING AND PLACEMENT SHALL WITH THE LATEST ACI STANDARDS.

GRATING: ALL STEEL FABRICATION SHALL BE IN ACCORDANCE TO AWA D1.1. STEEL SHALL BE ASTM A36 CARBON STEEL, AND HOT-DIPPED GALVANIZED AFTER FABRICATION IN ACCORDANCE TO ASTM A123

© ParkUSA. ALL RIGHTS RESERVED.



FLOATABLES COLLECTION SCREEN
HARRIS COUNTY - MODEL DSHD-HC

PM	PC	DRN	ENG	DWG. NO.	REV.
				DSHD-HC	A
DATE					

PLOTTED ON 4/22/2024 12:07 PM BY Vu, Kate, D:\File replacement, website\DSHD-HC