

ELEVATOR SUMP PUMP SYSTEM

General

The contractor shall furnish and install a ParkUSA EleVader Model ELV-XX complete pump, separator, and control and alarm system as shown on the drawings. Pump(s) shall be provided for each elevator hoistway.

The system shall be capable of pumping all water & fluids automatically from the elevator pit as required by ASME A17.1/CSA B44 Safety Code for Elevators and Escalators, 2007, Section 2.2.2.5. The system shall function automatically to remove water and fluids from the pit automatically without any human intervention. Systems that do not remove all the fluid including oil are not compliant and will not be accepted.

An oil-water separator or equivalent protection shall be used to treat oily wastewater automatically from the elevator pit prior to discharge into the public sanitary sewer as required. Pumping into the storm sewer is not permitted. Systems that do not remove the oil will not be accepted.

Sump Pump

A submersible sump pump is located in the sump area of the elevator (refer to plan drawings). The sump pump shall be as specified on the schedule, heavy duty submersible type, capable of pumping water, water/oil and oil at a minimum capacity of 50 GPM, (3000 GPH as per ASME A17.1 Section 2.2.2.5 (2007) and 100 GPM. The pump shall be constructed and tested to meet UL 778 standards and shall include thermal overload protection. Refer to the schedule for capacity and electrical requirements. The pump shall be capable of operating with the water level covering only 50% of the motor casing and shall operate automatically either continuously or intermittently as required by the on-off float switch control. The pump shall have a size 1-1/4" minimum discharge connection. The motor housing and fastening bolts shall be constructed of 304 Stainless Steel and have carbon ceramic seals. The pump shall have a semi-open, non-clogging Vortex impeller and shall be designed for floor mounting complete with support legs. A stainless chain shall be provided for easy maintenance.

Oil/Water Separator

The separator is located either freestanding; or recessed on floor near the shaft; or located outdoors buried below grade. Refer to the schedule for capacity and size requirements. The separator unit is rated from 50 to 200 GPM depending on the quantity of elevator shafts to be served, 50 GPM or 3000 GPH as per ASME A17.1 Section 2.2.2.5 (2007). The oil/water separator shall be a pre-engineered enhanced gravity separator capable of treating wastewater discharge free of petroleum hydrocarbons, concentration of less than 100 parts per million. Operating range of the influent is 40F to 180F and ambient air temperature from 0F to 140F. The specific gravity of the oils at these operating temperatures is .70 to .95. The separator shall be designed to withstand static and dynamic hydraulic loadings while empty and during operation. The tank shall be constructed of 4500 psi precast concrete conforming to ASTM C-913 for tanks, weirs, flow distributors, and energy dissipater devices. All internal components shall consist of corrosion resistant materials or be epoxy coated. All welding shall be in accordance with AWA d1.1 to provide watertight vessel that will not warp or deform excessively under load. Manway access cover shall be H-20 traffic duty, bolted and gasketed. The separator shall utilize coalescing media fabricated of calcium carbonate-filled oleophilic polypropylene plastic material and assembled into modules with 304 stainless steel materials. Media assembly shall be self-cleaning and removable.

Control System

The control system shall consist of float sensors and a single control panel (NEMA 4X weatherproof) that is wall mounted near the elevator shaft. The control panel shall be constructed and tested to meet UL508 standards and shall be housed in a weatherproof NEMA 4X electrical enclosure with a wiring terminal strip for field wiring to the J-Box in the hoistway.

The control panel shall have the following functions:

- a. Operates the sump pump, "On/Off" depending on shaft water levels. The panel shall have a "Hand-Off-Auto" switch, a "Pump Run" light, and auxiliary contacts for a BAS system.
- b. Indicates "Sump High Level" of the elevator shaft. In the event of pump malfunction, the panel shall have a "Sump High Level" illuminated red light and high decibel warning horn, a "Silence" switch and auxiliary dry contacts for BAS system.
- c. Indicates "High Oil Level" of the separator. In the event of a high accumulation of oil in the separator, the panel shall have a "Separator High Level" illuminated red light & high decibel warning horn, a "Silence" switch, and auxiliary dry contacts for BAS system. NOTE: The presence of oil DOES NOT prevent the pump from operating.

The panel also includes a separate over-current relay and field adjustable motor overload having a range of 5 to 15 amps, factory set at 8 amps for this pump application. The control panel shall have a combination manual "Reset/Push" to test switch for motor overload with both automatic, manual reset and control diagnostics. The control system must be factory set for automatic overload restart.

The control system shall include three field adjustable float switches located in the sump; Pump Off, Pump On, and High Level. Provide a factory prewired NEMA 6P watertight junction box with a din rail mounted wiring terminal strip. Provide factory installed wiring of pump and floats into a NEMA 6P junction box. All cables between the pump and junction box shall be a maximum of 6' long per NEC 2008. The cable shall be heavy usage, watertight and oil resistant. The floats and oil sensing probe shall be factory mounted on the pump housing. All cable entries into the J-Box from the pump pit shall have NEMA 6P watertight cord grips. The oil sensing probe is to be factory mounted and positioned within the separator and factory tested as a complete system.

Acceptable Manufacturers:

ParkUSA Elevader System, 888-611-PARK, www.Park-USA.com or Engineered pre-approved equal, provided all of the specifications are met.

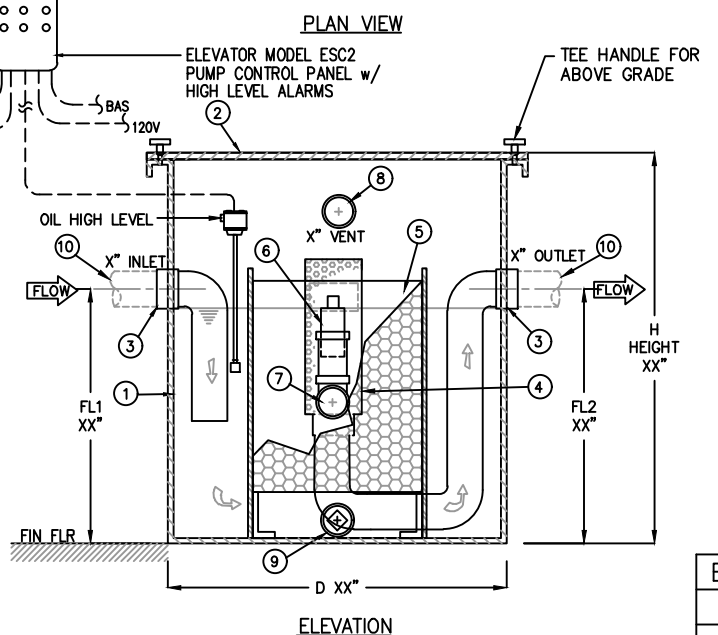
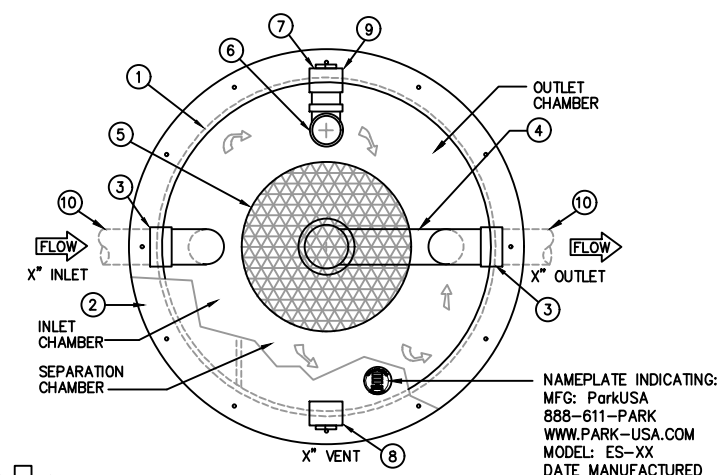

- NOTES**
- ① SEPARATOR BASIN WITH INTERIOR/EXTERIOR EPOXY FINISH
 - ② GASTITE REMOVABLE STEEL ACCESS COVER w/ NEOPRENE GASKET, SECURED w/ SS BOLTS AND QUICKTEE HANDLER
 - ③ 2", 3" OR 4" NPT STEEL FULL CPLG
 - ④ OIL/STOP-FLOW AUTOMATIC SHUT-OFF VALVE AT OUTLET PIPING
 - ⑤ OLEOPHILIC COALESCING PLATE PACK TO SEPARATE OIL & SOLIDS
 - ⑥ 1" ADJUSTABLE SKIMMER
 - ⑦ 2" OIL DRAIN - NPT FULL CPLG w/ PLUG
 - ⑧ 2" VENT - NPT HALF CPLG
 - ⑨ 2" DRAIN - NPT HALF CPLG w/ PLUG
 - ⑩ PIPING BY OTHERS

② ELEVATOR SEPARATOR DETAIL
NOT TO SCALE

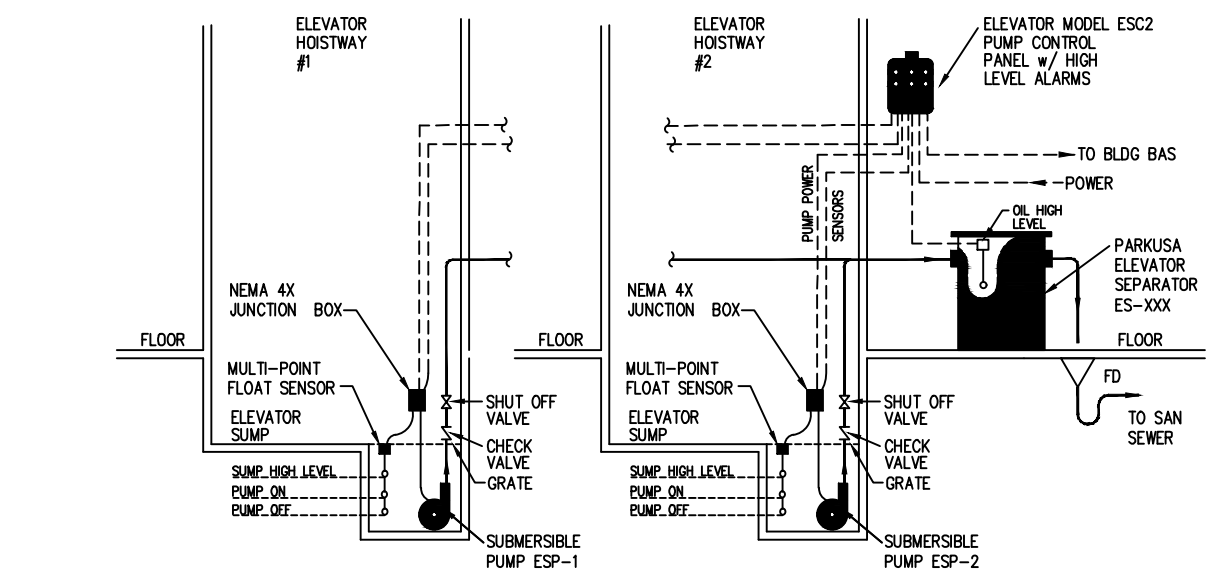

① ELEVATOR SUMP ESP-1 & 2 DETAIL
NOT TO SCALE (ABOVEGROUND SEPARATOR)

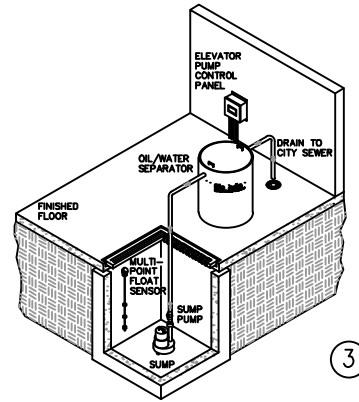

③ ELEVATOR SUMP SYSTEM SCHEDULE
NOT TO SCALE

SYSTEM MODEL		SEPARATOR DATA								SUBMERSIBLE PUMP DATA*					
SYSTEM SIZE	ELEVATORS PER HOISTWAY	SEPARATOR MODEL	FLOW CAP GPM	TOTAL CAPACITY	OIL SPILL CAPACITY	DIA D	HEIGHT H	INLET FL1	OUTLET FL2	FLOW CAP GPM	TDH	DISCH SIZE	RPM	HP	VOLT/PH
ELVS-100	1	ES-100	50	100 GAL	50 GAL	30"	44"	35"	32"	50	15'	1 1/4"	1750	.50	115/1
ELVS-150	2	ES-150	100	150 GAL	75 GAL	30"	60"	51"	48"	100	15'	1 1/4"	1750	.75	115/1 OR 230/1
ELVS-200	3	ES-200	150	200 GAL	100 GAL	30"	78"	69"	66"	150	15'	1 1/2"	1750	1.0	230/1 OR 230/460/3
ELVS-250	4	ES-250	200	250 GAL	125 GAL	36"	72"	63"	60"	200	15'	2"	1750	1.5	230/1 OR 230/460/3
ELVS-300	5	ES-300	250	300 GAL	150 GAL	36"	78"	69"	66"	CONTACT PARKUSA FOR PUMP SELECTION.					
ELVS-350	6	ES-350	300	350 GAL	175 GAL	42"	72"	63"	60"	CONTACT PARKUSA FOR PUMP SELECTION.					
ELVS-400	7	ES-400	350	400 GAL	200 GAL	48"	60"	51"	48"	CONTACT PARKUSA FOR PUMP SELECTION.					
ELVS-450	8	ES-450	400	450 GAL	225 GAL	48"	69"	60"	57"	CONTACT PARKUSA FOR PUMP SELECTION.					
ELVS-550	10	ES-550	500	550 GAL	275 GAL	48"	81"	72"	69"	CONTACT PARKUSA FOR PUMP SELECTION.					

* NOTE: PUMP INFORMATION IS SHOWN AS GUIDELINE. EXACT PUMP SPECIFICATIONS DEPEND ON APPLICATION FLOW AND HEAD REQUIREMENTS.

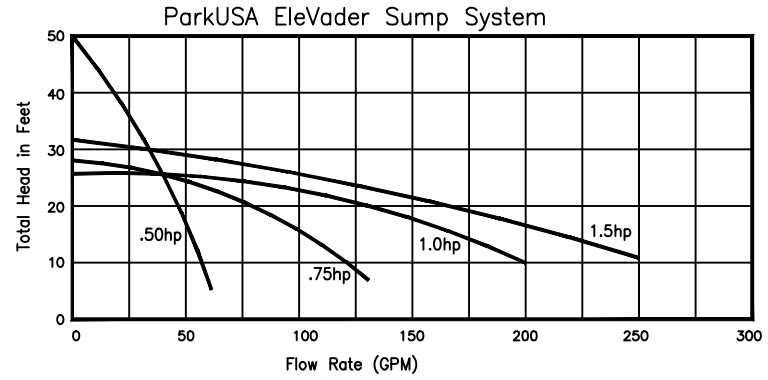

④ PUMP CURVE
NOT TO SCALE



ELEVATOR SUMP SYSTEM - TWO (2) HOISTWAY
MODEL ELVS

PM	PC	DRN	ENG	DWG. NO.	REV.
				ELVS-2H-DD-WA	A
DATE	5/24				

LAST MODIFIED BY KVV ON 7/23/2024 2:32 PM; LAST PLOTTED ON 7/23/2024 2:33 PM BY WJ, KATE; FILE NAME: ELVS-2H-DD-WA.DWG

© ParkUSA. ALL RIGHTS RESERVED.