

KEYED NOTES		
MARK	QTY	DESCRIPTION
1	1	SAND-OIL SEPERATOR
2	1	OIL CHAMBER
3	1	INTEGRAL OIL STORAGE COMPARTMENT
4	1	COALESCING-MEDIA PACK
5	1	INTERIOR BITUMASTIC
6	1	SLUDGE BAFFLE
7	1	DIFFUSION BAFFLE
8	1	OIL DAM PIPING
9	1	SLUDGE CHAMBER
10	2	RESILIENT BOOT
11	2	X" INPUT AND OUTPUT
12	1	NAMEPLATE INDICATING: MFG: ParkUSA 888-611-PARK MODEL: HFSC-01 DATE MANUFACTURED
13	1	30 X 60 GALVANIZED STEEL PARKway.
14	1	3/4" CONDUIT SLEEVE
15	1	FRAME AND GRANITE SHIPPED LOOSE
16	1	3" VENT
17	1	4" VENT

SAND-OIL INTERCEPTOR SCHEDULE

MODEL NO.	CAPACITY USGal	OIL CAP. US (GAL)	EMPTY WT (LBS)	LENGTH L1	WIDTH W1	HEIGHT H1	INLET FL1	OUTLET FL2
SOCMP-500	500	250	8,000	7'-10"	4'-4"	4'-6"	3'-3"	3'-0"
SOCMP-750	750	375	10,000	7'-10"	4'-4"	6'-0"	4'-5"	4'-2"
SOCMP-1000	1,000	500	13,200	8'-8"	5'-0"	6'-0"	4'-9"	4'-6"
SOCMP-1500	1,500	750	20,000	9'-2"	5'-8"	7'-0"	5'-9"	5'-6"

OTHER SIZES ARE AVAILABLE. CONTACT US FOR MORE INFORMATION

- APPLICATIONS**
- MAINTENANCE WASHDOWN & GARAGES
 - GOLF COURSES
 - EQUIPMENT & TRANSPORTATION WASHDOWN FACILITIES
 - CARWASHES
 - STORMWATER RUNOFF
 - SERVICE STATION FUEL DEPOTS
 - MANUFACTURING FACILITY EFFLUENT WATER
 - REMEDIATION WATER CLEANUP
 - GENERAL INDUSTRY

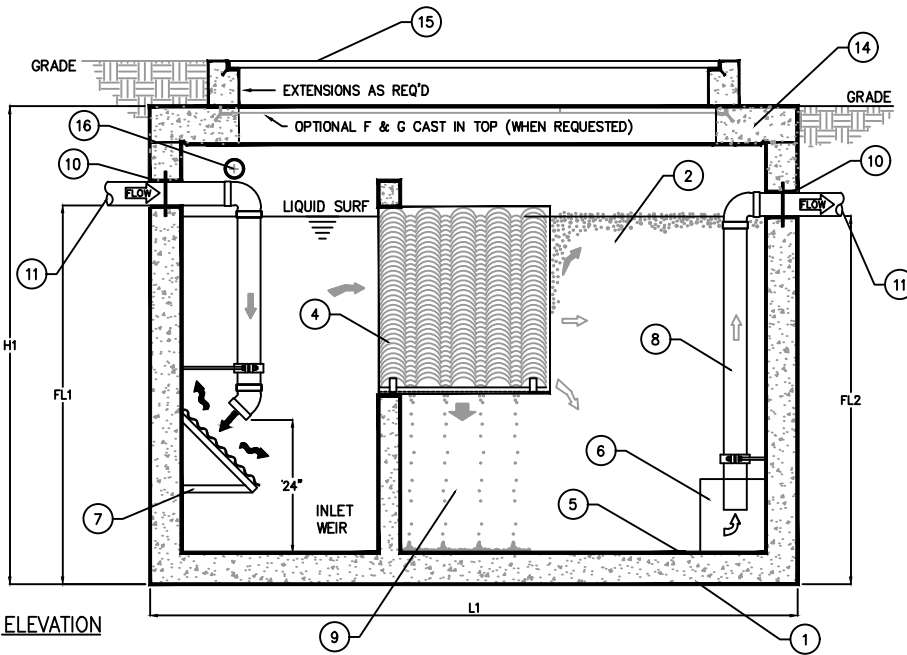

GUARANTEED PERFORMANCE

A certified performance analysis utilizing a proprietary computer program will accurately model systems to ensure that their effluent qualities meet the required discharge criteria (EPA and Local Codes)

Influent oily water contains oil droplets of many different sizes. These droplets rise at different rates. Park utilizes a statistical program that divides the droplets into ranges of sizes and calculates the rise rates of each range. This calculation determines which droplets the separator can capture.

GUARANTEED PERFORMANCE FOR CODE MAXIMUM OIL CONCENTRATION (SANITARY SEWER 400 PPM, STORM SEWER 15 PPM)



SPECIFICATIONS

- CONCRETE:** CLASS I/II CONCRETE WITH DESIGN STRENGTH OF 4500 PSI AT 28 DAYS. UNIT IS OF MONOLITHIC CONSTRUCTION AT FLOOR, FIRST STAGE OF WALL AND BAFFLE WITH SECTIONAL RISER TO REQUIRED DEPTH. GROSS EMPTY WEIGHT OF APPROXIMATELY 65,000 LBS.
- REINFORCEMENT:** GRADE 60 REINFORCED WITH STEEL REBAR CONFORMING TO ASTM A615 ON REQUIRED CENTERS OR EQUAL. STRUCTURAL DESIGN IS BASED ON AASHTO HS-20 LOADING.
- C.I. CASTINGS:** MANHOLE FRAMES, COVERS OR GRATES ARE MANUFACTURED OF GREY CAST IRON CONFORMING TO ASTM A48-76 CLASS 30. MANHOLE SHALL HAVE 24 INCH INSIDE DIAMETER AND BE TRAFFIC DUTY.

ENGINEERING DATA

INTERCEPTOR IS STRUCTURALLY AND HYDRAULICALLY ENGINEERED. NOMINAL LIQUID CAPACITY IS 7,000 GALLONS. FIELD EXCAVATION AND PREPARATION SHALL BE COMPLETED PRIOR TO DELIVERY OF INTERCEPTOR. USE DIMENSIONAL DATA AS SHOWN.



SAND-OIL SEPARATOR
SOCMP

PM	PC	DRN	ENG	DWG. NO.	REV.
				SOCMP-1	A
DATE	2023				

CREATED ON 12/15/2023 BY ...
LAST MODIFIED ON 12/15/2023 9:43 AM BY chowen

PLOTTED ON 1/22/2024 10:00 AM BY Jennings, Jonathan. Y:\ParkUSA\WebSite 2022 - NEED TO GO\SOCMP-1-UPDATED-2022

© ParkUSA. ALL RIGHTS RESERVED.