

MODEL PH1R REMOTE PH101 ANALYZER WITH DIGITAL RECORDER, VAULT MOUNTED IN NEMA 4X SURFACE MTD ENCLOSURE (MTD IN BLDG)

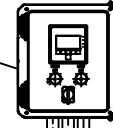

120 VAC POWER SUPPLY  
-BAS

pH, TEMPERATURE, SENSOR CABLES 22AWG/SHIELD/PP X2

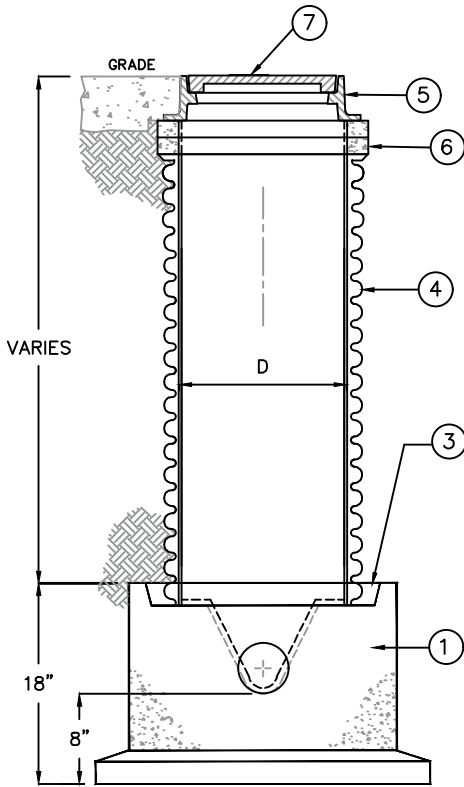

FRONT VIEW

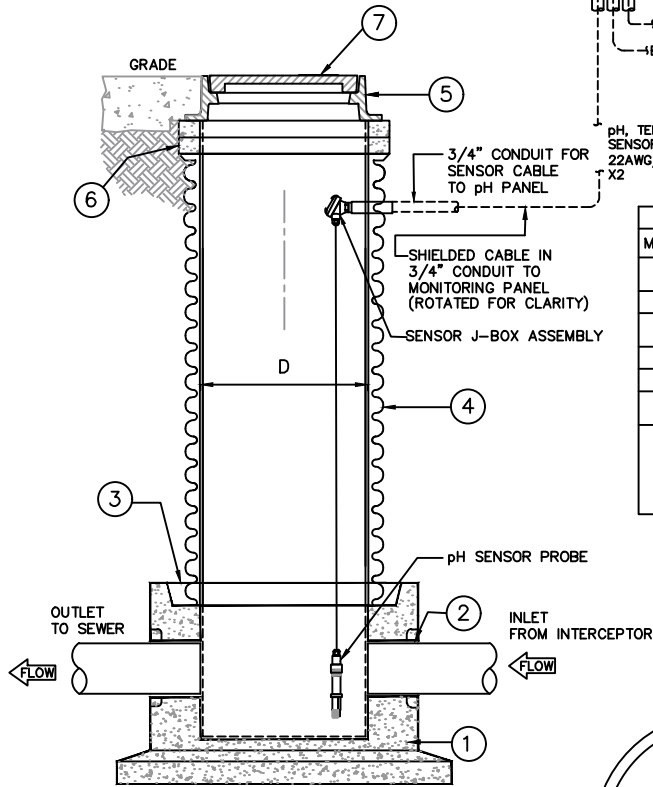

SIDE VIEW

KEY NOTES		
MARK	QTY	DESCRIPTION
1	1	CONCRETE BASE W/ HDPE INTERIOR LINER
2	2	SCH 40 PVC SLEEVE (TYP)
3	-	JOINT SEALED W/ NON-SHRINK GROUT
4	1	RISER SECTION HDPE PIPE
5	1	CAST IRON RING & COVER
6	-	CONCRETE EXTENSION RINGS AS REQUIRED
7	1	NAMEPLATE INDICATING: MFG: PARKUSA.COM 888-611-PARK MODEL: SWBP-PH DATE: MANUFACTURED

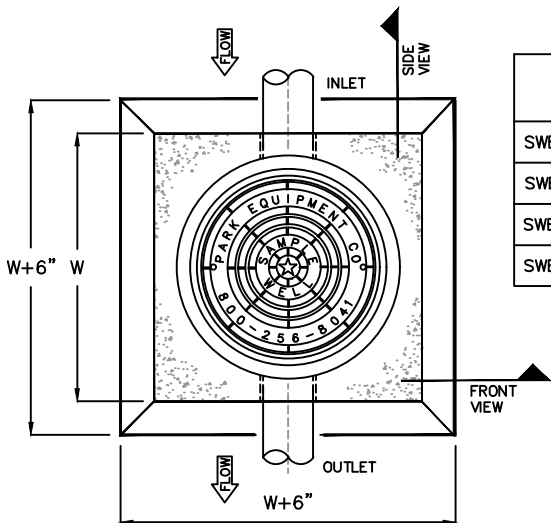

PLAN VIEW

MODEL	DIAMETER "D"	IN & OUT PIPE SIZE	WIDTH "W"
SWBP-PH-154	18"	4"	28"
SWBP-PH-156	18"	6"	28"
SWBP-PH-244	24"	4"	34"
SWBP-PH-246	24"	6"	34"

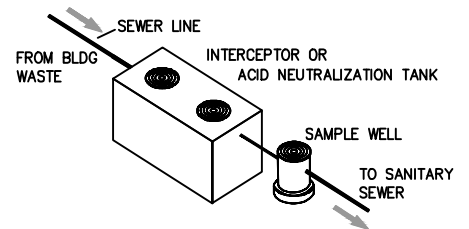

SAMPLE APPLICATION

SPECIFICATIONS

CONCRETE: DESIGN STRENGTH OF 4500 PSI AT 28 DAYS. UNIT IS OF MONOLITHIC CONSTRUCTION AT FLOOR AND FIRST STAGE OF WALL WITH SECTIONAL RISER TO REQUIRED DEPTH.

C.I. CASTINGS: CAST IRON FRAMES AND GRATES ARE MANUFACTURED OF GREY CAST IRON CONFORMING TO ASTM A48-76 CLASS 30, HEAVY-DUTY AASHTO H-20



pH MONITORING SAMPLE WELL  
MODEL SWBP-PH

PM	PC	DRN	ENG	DWG. NO.	REV.
				SWBP-PH-WA	A
DATE				4/24	

LAST MODIFIED BY KJU ON 4/19/2024 11:06 AM. LAST PLOTTED ON 4/19/2024 11:06 AM BY WJ. KATE. FILE NAME: SWBP-PH-WA.DWG

© ParkUSA. ALL RIGHTS RESERVED.